

SE Current Monitoring Series H921-S6



SPECIFICATIONS

Sensor Power	30 mA (max.)@12-30 VDC
Amperage Range	0 to 30/60/120 A (slide switch selectable)
Sensor Output.	4-20 mA
Response Time.	2 sec.
Insulation Class	300 VAC RMS, insulated conductors only
Frequency.	50/60 Hz
Temperature Range	-15° to 60°C (5° to 140°F)
Humidity Range.	10-90% RH non-condensing
Accuracy.	±2% FS from 10% to 100% of selected range
Terminal Block Wire Size	0.2 to 2.1 mm ² (24 to 14 AWG)
Terminal Block Torque	0.4 to 0.5 N-m (3.5 to 4.4 in-lb)
Agency Approvals	CE:EN61010-1:2001
Installation Category.	Cat. III, pollution degree 2

For CE compliance, conductor shall be insulated according to IEC 61010-1:2010. The product design provides for basic insulation only.

The Schneider Electric H921-S6 is a current transducer that senses current (amperage) in any of three field-selectable ranges: 0-30, 0-60, or 0-120 amperes. These ranges represent the maximum current that can be applied to the monitored conductor. The H921-S6 transforms the monitored current value into a 4-20 mA output suitable for connection to building controllers or other appropriate data acquisition equipment. The H921-S6 requires 12-30 VDC external power to generate its output.

DIMENSIONS

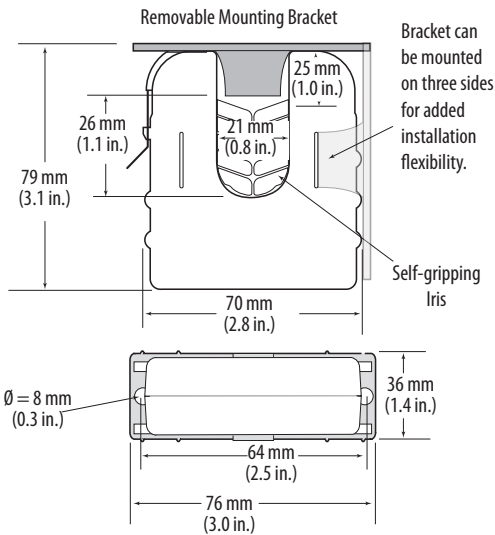

⚠️ ⚠️ DANGER

HAZARD OF ELECTRIC SHOCK, EXPLOSION, OR ARC FLASH

- Follow safe electrical work practices. See NFPA 70E in the USA, or applicable local codes.
- This equipment must only be installed and serviced by qualified electrical personnel.
- Read, understand and follow the instructions before installing this product.
- Turn off all power supplying equipment before working on or inside the equipment.
- Use a properly rated voltage sensing device to confirm power is off.
DO NOT DEPEND ON THIS PRODUCT FOR VOLTAGE INDICATION
- Only install this product on insulated conductors.

Failure to follow these instructions will result in death or serious injury.

A qualified person is one who has skills and knowledge related to the construction and operation of this electrical equipment and the installation, and has received safety training to recognize and avoid the hazards involved. NEC2009 Article 100
 No responsibility is assumed by the manufacturer for any consequences arising out of the use of this material.

NOTICE

- This product is not intended for life or safety applications.
- Do not install this product in hazardous or classified locations.
- The installer is responsible for conformance to all applicable codes.
- Mount this product inside a suitable fire and electrical enclosure.

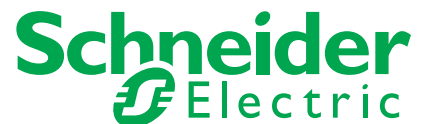

INSTALLATION

Disconnect and lock out power to the enclosure containing the conductor to be monitored.

1. Locate a mounting surface for the removable mounting bracket that will allow the monitored conductor to pass through the center window when it is installed and that will keep the product at least 13 mm (½ in.) from any uninsulated conductors. Determine cable routing for the controller connection, allowing wiring to reach the mounting location.
2. Drill holes to mount the bracket to the chosen surface using the included screws.
3. Wire the output connections between the sensor and the controller (4-20 mA).
4. Snap the sensor over the wire to be monitored and clip the assembly to the mounting bracket.
5. Select the desired amperage range on the transducer.
6. Secure the enclosure and reconnect power.
7. Scale the controller software to match the transducer output.

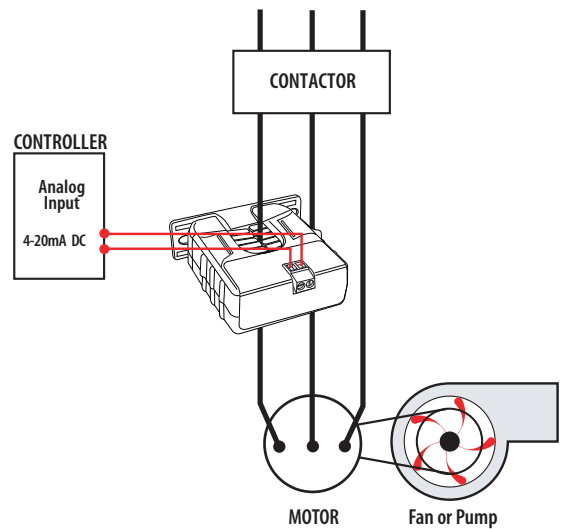

WIRING EXAMPLES

External Power

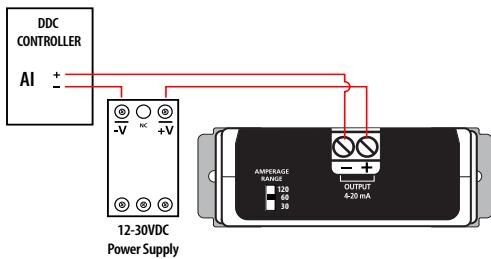

Sourcing Panel (- Common)

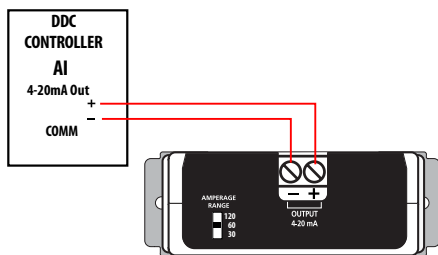

Sinking Panel (+ Common)

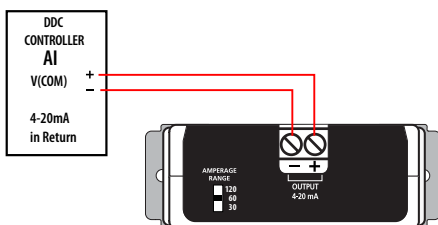

SCALING

Set the amperage range selector switch to a level appropriate for the application load, 0-30, 0-60, or 0-120 Amps.

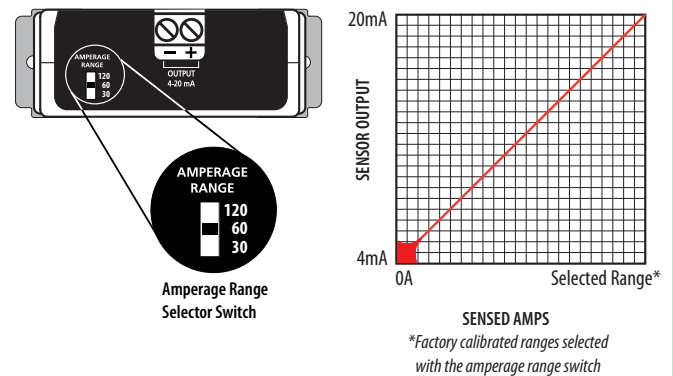

LOW CURRENT APPLICATIONS

For load currents less than sensor minimum rating, wrap the monitored conductor through the center window and around the sensor body to produce multiple turns. This increases the current measured by the transducer. Program the controller to account for the extra turns, e.g., if four turns pass through the sensor, then divide the reading by 4.

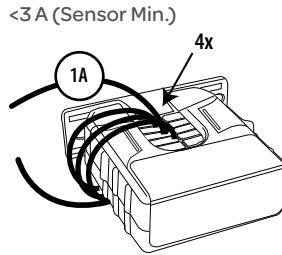

CAUTION

RISK OF EQUIPMENT DAMAGE

- Configure any input wrapping for the number of turns through the current sensor window using the following formula:
Rated Max. Amps ÷ Number of Turns = Max. monitored Amps
 e.g. : 100A ÷ 4 Turns = 25 Amps max. in monitored conductor
- Never exceed the current sensor rating.
- Failure to follow these instructions can result in overheating and permanent equipment damage.

HIGH CURRENT APPLICATIONS

For load currents greater than sensor maximum rating, use a 5 Amp current transformer (CT) as shown. This technique can be combined with wrapping (see above). Select an amperage range on the current sensor that matches the CT maximum output (accounting for any wrapping) to enable the entire current sensor output range. Do not exceed the current sensor rating.

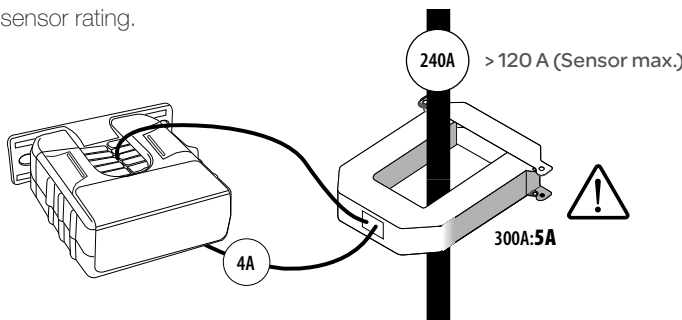

! DANGER: 5A CTs can present hazardous voltages. Install CTs in accordance with manufacturer's instructions. Terminate the CT secondary before applying current.

TROUBLESHOOTING

PROBLEM	SOLUTION
No Reading at Controller	<ul style="list-style-type: none"> • Confirm that a 12-30 VDC supply is connected in series with the sensor output terminals and the control panel analog input. • Confirm measured current is within the selected range. • Check polarity of the sensor output connections. • Assure that sensor core mating surfaces are clean and that the core clamp is completely closed.

PRODUCT INFORMATION

Ordering Code	Model Number	Description
324-0203-000	H921-S6	I-Xdcr,SP,30/60/120AAC:4-20mA